



Version 4.6

## Impairment Emulator Software for IP Networks (IPv4 & IPv6)

The screenshot shows the NetDisturb Client software interface. The main window is titled "NetDisturb Client - Impairment Tool for IP Networks - C:\Program Files\NetDisturbClient\Default.WSX". The interface is divided into several sections:

- IP Flows:** A list of 16 flow configurations (Stop #01 to #16) with various triggers like "TCP/Port 2009" to "TCP/Port 2024".
- IP Flow #01: TCP/Port 2009:** The active flow configuration. It shows a "Waiting for the trigger" status. The configuration includes:
  - Loss & Duplication Law:** TCP 2009, Percentage of Loss, Loss: Percentage.
  - Delay & Jitter Law:** Router Simulation with Delay, Router Simulation & Constant Delay.
  - Statistics:** # Incoming Packets: 0, # Lost or Duplicated Packets: 0, # Delayed Packets: 0.
- Interface A (MAC: 00 08 A1 36 1C 7A):** Shows incoming and outgoing traffic with 0 p/s and 0.00 b/s throughput.
- Interface B (MAC: 00 08 A1 36 11 59):** Shows incoming and outgoing traffic with 0 p/s and 0.00 b/s throughput.
- Aggregates:** A list of 16 aggregate configurations, mostly set to "(None)".
- Total Synthesis:** A table showing overall network performance.

|             | Throughput Reception | Received Pkts | Matching Pkts | Sent Pkts | Throughput Transmission | Alarms |
|-------------|----------------------|---------------|---------------|-----------|-------------------------|--------|
| From A to B | 0.00 b/s             | 0 p/s         | 0 p           | 0 p       | 0.00 b/s                | 0 p/s  |
| From B to A | 476 b/s              | 1 p/s         | 2 p           | 2 p       | 476 b/s                 | 1 p/s  |

CPU Usage: 3%

## Performance Characteristics on Gigabit networks

## Abstract

To measure the performance of impairment emulation software one needs to consider multiple aspects. Performance is mainly linked to:

- A- Physical throughput
- B- Number of packets sent per second

These metrics determine the capability of the impairment emulator not to introduce unhandled impairments, other than the user defined impairments, due to software limitations. This document summarizes results achieved with **NetDisturb V4.6** for a Gigabit Ethernet configuration with copper interface. Tests were conducted at the ZTI Test Lab.

## 1 Introduction

This document provides an overview of performance that can be expected from **NetDisturb** with the same configuration as tested in our lab. Users may get better performance than the one presented in this document with a more powerful PC, with other Ethernet architectures or NICs.

For our tests, a Server PC was used. A Gigabit network needs fast PCs to make tests. We selected PCs that guarantee efficient CPU, memory and disk subsystem architecture. On our system, we installed Windows XP Pro with Service Pack 2.

**LanTraffic V2** is used to generate IP flows. This choice is based on the simplicity of this software to create a strong flow even from desktop computers. **LanTraffic V2** is running under Windows Vista to get the highest performances on the gigabit network.

**NetDisturb** version 4.6.2 is used for all tests. Do not activate any software other than **NetDisturb** to avoid decreasing the CPU availability. Note that antivirus software and/or Windows Firewall should be switched off in order to obtain the best performance.

This document is organized as follows:

- **Throughput Measurements Results**

This section shows the results obtained in our labs.

- **Description of the two tests benches**

This section describes the architecture of the two tests benches used and the parameters used.

- **Appendix**

This section provides additional information regarding hardware configurations.

## 2 Throughput Measurements Results

More details about the configurations used can be found in § 3 Description of the two tests benches.

### 2.1 Throughput Measurements

Table 1 shows the maximum throughput that **NetDisturb** can handle. These results were obtained with the configuration 1 (refer § 3.1 Configuration 1: Throughput Performance Measurements)

| Number of IP flows activated | Incoming and Outgoing Throughput* |
|------------------------------|-----------------------------------|
| 0 (Other IP Flows activated) | 980 Mb/s                          |
| 1                            | 980 Mb/s                          |
| 16                           | 975 Mb/s                          |

Table 1 - Gigabit measurements with TCP packets

| Number of IP flows activated | Incoming and Outgoing Throughput* |
|------------------------------|-----------------------------------|
| 0 (Other IP Flows activated) | 970 Mb/s                          |
| 1                            | 970 Mb/s                          |
| 16                           | 970 Mb/s                          |

Table 2 - Gigabit measurements with UDP packets

\* Throughput data is based on the MAC level data, i.e. it's the Ethernet throughput.

### 2.2 Packets Throughput Measurements

Table 2 shows the maximum number of packets per second that **NetDisturb** can handle. These results were obtained with the configuration 1 (refer § 3.2 Configuration 2: Packets Throughput Performance Measurements)

| Number of IP flows activated | Incoming and Outgoing Throughput |
|------------------------------|----------------------------------|
| 0 (Other IP Flows activated) | 201 000 packets/s                |
| 1                            | 192 000 packets/s                |
| 16                           | 156 000 packets/s                |

Table 3 - Gigabit measurements with UDP packets (Ethernet Frame size: 47 bytes)

| Number of IP flows activated | Incoming and Outgoing Throughput |
|------------------------------|----------------------------------|
| 0 (Other IP Flows activated) | 175 000 packets/s                |
| 1                            | 168 000 packets/s                |
| 16                           | 126 000 packets/s                |

Table 5 - Gigabit measurements with UDP packets (Ethernet Frame size: 546 bytes)

| Number of IP flows activated | Incoming and Outgoing Throughput |
|------------------------------|----------------------------------|
| 0 (Other IP Flows activated) | 192 000 packets/s                |
| 1                            | 185 000 packets/s                |
| 16                           | 150 000 packets/s                |

Table 4 - Gigabit measurements with UDP packets (Ethernet Frame size: 206 bytes)

| Number of IP flows activated | Incoming and Outgoing Throughput |
|------------------------------|----------------------------------|
| 0 (Other IP Flows activated) | 80 000 packets/s                 |
| 1                            | 80 000 packets/s                 |
| 16                           | 80 000 packets/s                 |

Table 6 - Gigabit measurements with UDP packets (Ethernet Frame size: 1518 bytes)

#### CPU and bus type are critical elements

The number of CPUs and the hyper threading systems help to handle interruptions generated by packets exchanges. Capacity to handle interruptions limits the number of packets that can be exchanged. During those tests the CPU usage was around 40%.

#### Hardware component quality is crucial to obtain the best performance

During tests up to 308 000 packets/s have been generated but only around 200 000 packets/s were received by **NetDisturb**. This might be due to limitations of the network adapter. Best performance can be expected with more efficient NICs.

### 3 Description of the two tests benches

#### 3.1 Configuration 1: Throughput Performance Measurements

PC1 sends data to PC2 and PC3. **NetDisturb** is installed on PC4. All PCs are linked to the DLink Gigabit Switch using category 6 draft 10 cables. A Category 6 draft 10 cross cable is used to link PC1 and PC4.

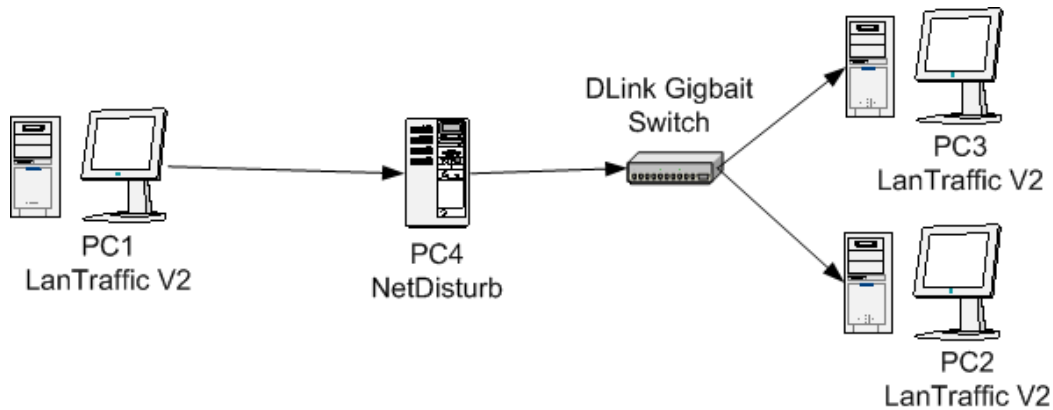

**LanTraffic V2** Unitary Testing Mode is selected and the default values (menu File/new) are kept except for these particular values listed hereafter:

|      | TCP Data Size | UDP Data Size |
|------|---------------|---------------|
| IPv4 | 1460 bytes*   | 1472 bytes*   |

\*This is the maximum data size required to prevent IP fragmentation which could decrease performance.

#### 3.2 Configuration 2: Packets Throughput Performance Measurements

PC1, PC2 and PC3 send data to PC5. **NetDisturb** is installed on PC4. All PCs are linked to the DLink Gigabit Switch using category 6 draft 10 cables. A Category 6 draft 10 cross cable is used to link PC4 and PC5.

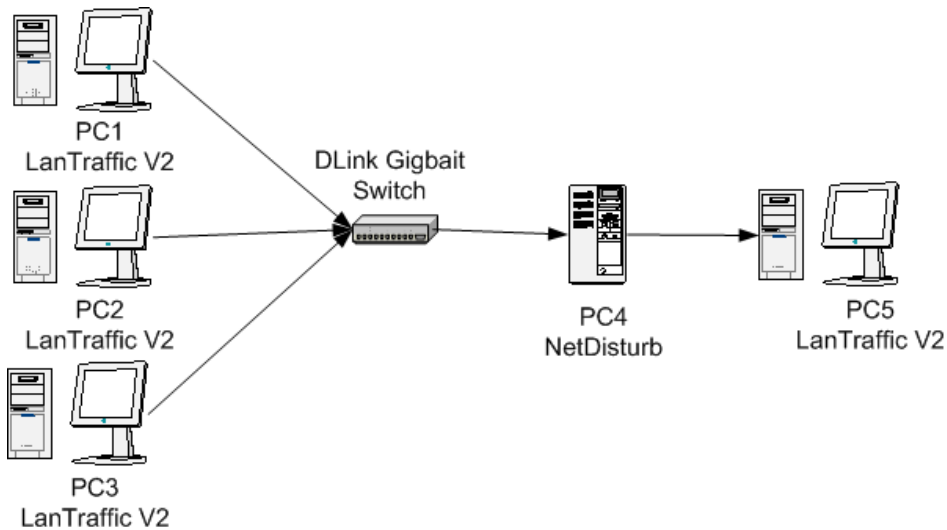

**LanTraffic V2** Unitary Testing Mode is selected and the default values (menu File/new) are kept except for these particular values listed hereafter. Different UDP data sizes are used to realize these tests.

| UDP Data Size | 1 byte | 160 bytes | 500 bytes | 1472 bytes* |
|---------------|--------|-----------|-----------|-------------|
|---------------|--------|-----------|-----------|-------------|

\*This is the maximum data size required to prevent IP fragmentation which could decrease performance.

## 4 Appendix

### PC1

- Manufacturer: DELL OptiPlex GX745
- Operating System: Windows Vista, Service Pack 1
- CPU: Intel Dual Core 2 E6600 2.4 Ghz
- RAM: 1 GB
- NIC: Broadcom NetXtreme Gigabit Ethernet PCI Express Adapter (ASIC Version: BCM 5751 C1)

### PC2

- Manufacturer: DELL OptiPlex GX280
- Operating System: Windows Vista, Service Pack 1
- CPU: Intel Pentium 4 - x86 family 15 Model 4 Stepping 1 GenuineIntel~3 Ghz with Hyper threading activated
- RAM: 1 GB
- NIC: Broadcom NetXtreme Gigabit Ethernet PCI Express Adapter (ASIC Version: BCM 5751 C1)

### PC3

- Manufacturer: DELL Power Edged 1600
- Operating System: Windows Server 2003, Service Pack 1
- CPU: 2 Intel Xeon 3 GHz
- RAM: 1 GB
- NIC: Broadcom NetXtreme 57xx Gigabit Ethernet Adapter (Embedded)

### PC4

- Manufacturer: DELL Power Edged 1900
- Operating System: Windows XP Professional Version 2002, Service Pack 2
- CPU: 2 Intel Xeon Dual Core 5140
- RAM: 1 GB (667 Mhz)
- NICs: 2 Intel Pro/1000 PT Server Adapter (PCI Express)

### PC5

- Manufacturer: DELL Power Edged 1750
- Operating System: Windows XP Professional Version 2002, Service Pack 2
- CPU: 2 Intel Xeon Dual Core 5140
- RAM: 1 GB (667 Mhz)
- NIC: Broadcom NetXtree 57xx Gigabit Adapter (Embedded)

### DLink Gigabit switch DGS 1004T

- Ethernet/Fast Ethernet/Gigabit Ethernet auto-sense
- Full duplex 10/100/1000 capabilities
- 4 ports 10/100/1000 Mbps